

4

3

2

1

REVISIONS				
ZONE	REV	DESCRIPTION	DATE	APPROVED
	-	INITIAL RELEASE		

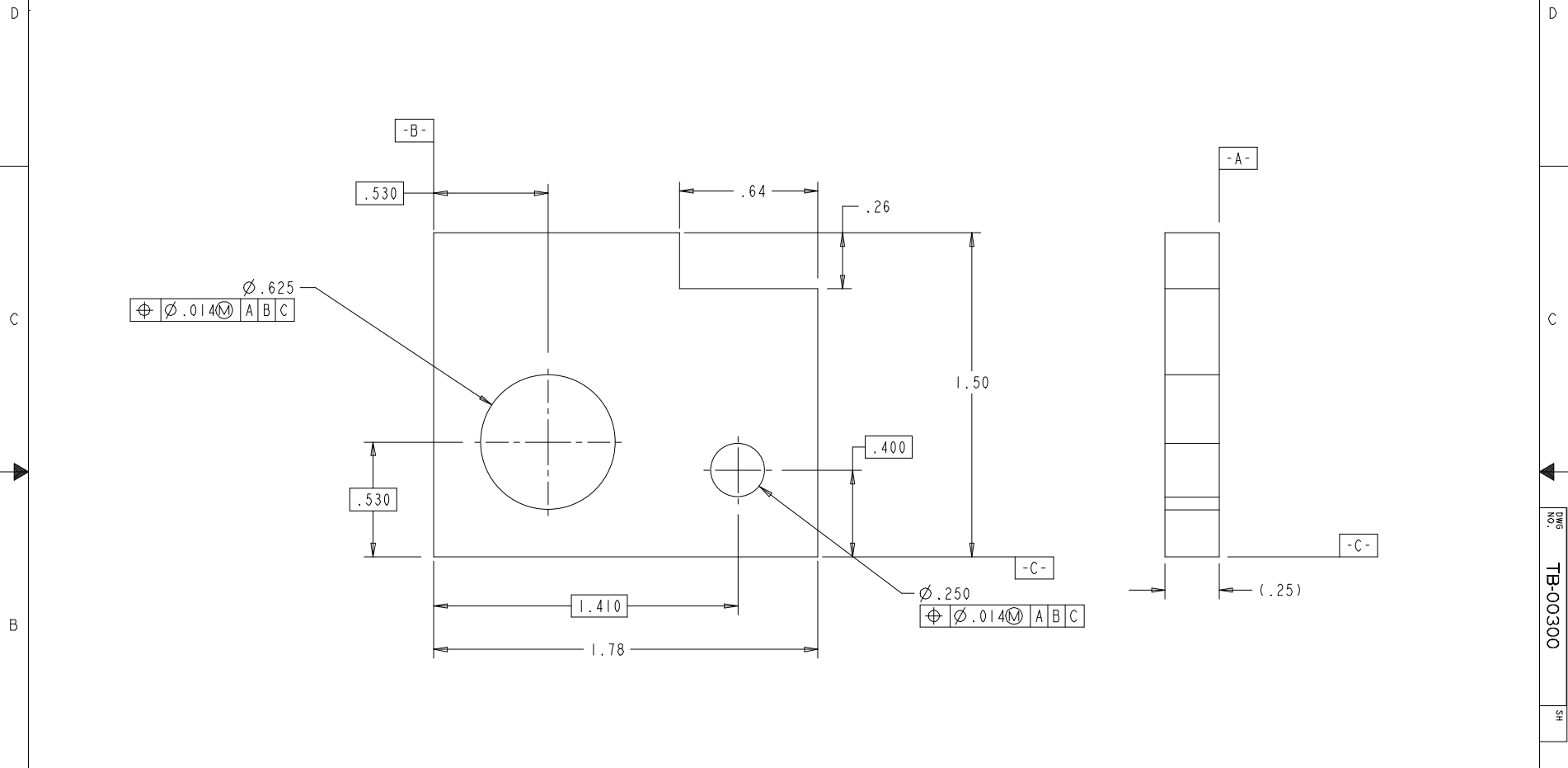

DWG NO. TB-00300

SH

		MFG REF. NO.		CONTRACT		DETAIL																		
		INTERPRET DIMENSIONS AND TOLERANCES PER ASME Y14.5M-1994		UNLESS OTHERWISE SPECIFIED, DIMENSIONS ARE IN INCHES; TOLERANCES: ANGLES ± 2 2 PL DEC ± .02 3 PL DEC ± .010		DRAWN BY JAY ELLER	DATE 04JUN02																REV SHEET INDEX	
		MATERIAL		MATERIAL, PROCESS, FINISH, SEE 00.40.		DESIGNED BY JAY ELLER	DATE 04JUN02	26	25	24	23	22	21	20	19	18	17	16	15	14		REV SHEET INDEX		
REF SPEC		.25 THICK MILD STEEL				CHECKED BY	DATE	13	12	11	10	9	8	7	6	5	4	3	2	1		REV SHEET INDEX		
		PROCESS				APVD FOR MFG	DATE	TOYBOX OFFROAD															22010 N. 23RD AVE PHOENIX, AZ 85027	
		FINISH		NONE		APVD FOR GE	DATE	TITLE															PLATE, TWIN STICK SHIFTER, LEFT	
		NEXT ASSY		USED ON (SYS)		DWG CLASS	A	DRAWING NO. TB-00300															REV -	
REF DWG		APPLICATION				FIRST USED ON	DATE	SCALE 3:1 UNIT WT															SHEET OF	

REV 06-09-98

COMPUTER GENERATED

3

2